

ACTUATOR CLOSED STATE

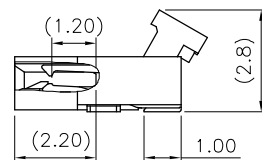

ACTUATOR OPENED STATE

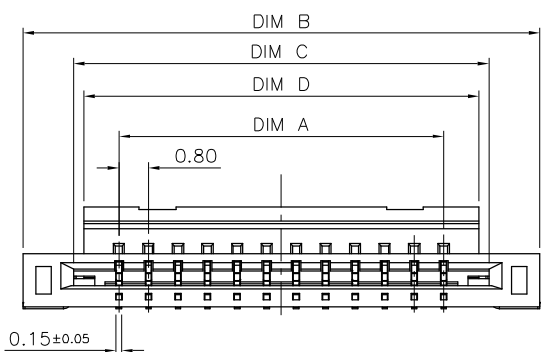
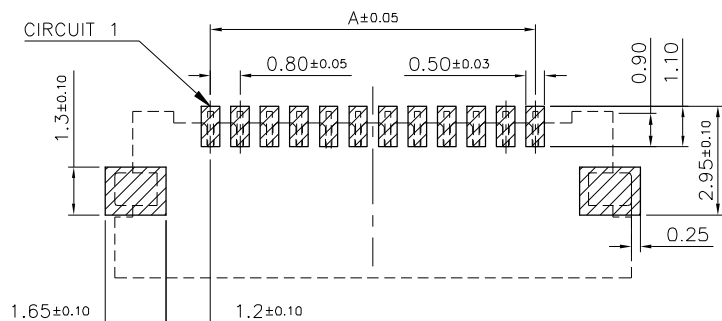

RECOMMENDED PC BOARD PATTERN DIM. (REF.)

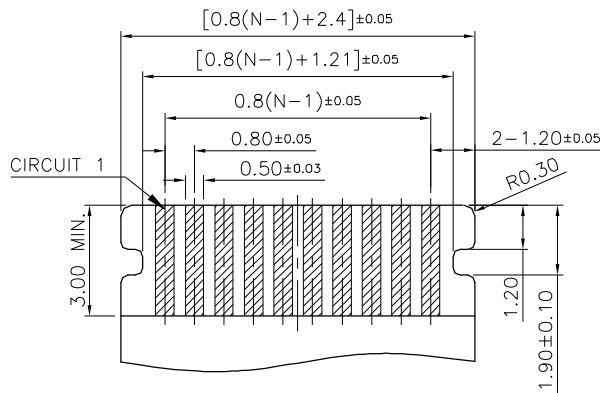

APPLICABLE FPC (THICKNESS: 0.2±0.03)

NOTES:

1. MATERIAL:
 - 1.1 HOUSING: THERMOPLASTIC, HIGH TEMP.,UL94V-0; COLOR:NATURAL.
 - 1.2 ACTUATOR: THERMOPLASTIC, HIGH TEMP.,UL94V-0; COLOR:BLACK.
 - 1.3 CONTACT: COPPER ALLOY
 - 1.4 FITTING NAIL: COPPER ALLOY
2. FINISH:
 - 2.1 CONTACT:50u" MIN. NICKEL PLATING OVERALL, 1: GOLD PLATED ON CONTACT; N: 100~200u" MATT TIN PLATING
 - 2.2 FITTING NAIL:50u" MIN. NICKEL UNDERPLATING OVERALL, 80~150u" MATT TIN PLATING.
3. REFLOW SOLDER CAPABLE TO 260°C PER ACES SPEC.
4. SPEC. PLS. REFER TO PS-51631-XXXXX-XXX.
5. PACKAGE PLS. REFER TO 51631-XXXXX-00-TRP.
6. PART NUMBER

51631-XXX X X-XXX

NO OF CKT	HOUSING MATERIAL&COLOR	ACTUATOR MATERIAL&COLOR	HALOGEN FREE
001	HF & NATURAL	HF & BLACK	HF

PACKING
0: TAPE & REEL

PLATING
1: GOLD PLATED ON CONTACT
N: MATT TIN

CKT	Dim A	Dim B	Dim C	Dim D
30	23.20	28.40	25.65	25.10

QUALITY SYMBOLS	DRAWN BY	DATE	ACES ELECTRONICS	
MAJOR Ⓢ	Ding,shujin	21/08/17	TITLE 0.8 PITCH EASY ON FPC CONN H=1.5mm SMT R/A TYPE	
CRITICAL Ⓢ	CHECKED BY	DATE		
GENERAL TOLERANCES (UNLESS SPECIFIED)	Lu, Jing Qian	21/08/17	UNITS	SIZE
X ±0.5	APPROVED BY	DATE	mm	A4
X ±0.25	hsieh, fu yu	21/08/17	SCALE	REV
.XX ±0.15			1:1	A
.XXX ±0.1			SHEET NO.	DFWG NO.
ANGLES ±2°			1 OF 1	51631-XXXXX-XXX